

1LC

Fusion Capability for 1/2" CTS to 1" IPS (16mm - 34mm)

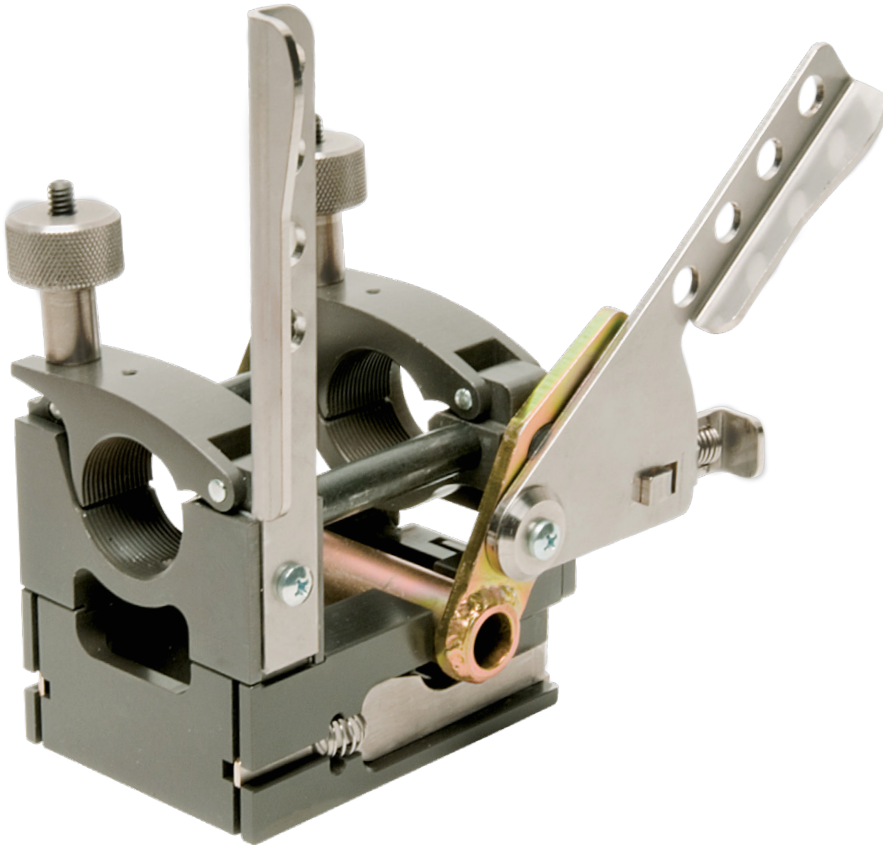

OVERVIEW

The 1LC can butt fuse 1/2" CTS to 1" IPS (16mm to 34mm) service sizes. The 1LC offers a more conventional style of operation than the Mini-Mc®.

McElroy engineers designed the heater to locate on guide rods built into the unit, similar to the entire line of McElroy fusion machines. The compact design also allows for fusing in tight confines.

If you previously owned a Mini-Mc, the inserts you own for the Mini-Mc will work in the 1LC.

FEATURES

- Locking cam to maintain force during the cooling cycle
- Conventional facer design features ball-bearing construction and gear drive for long life
- 3.8-to-1 mechanical advantage
- Jaws use same inserts as original Mini-Mc
- Serrated jaws and inserts keep pipe from slipping during fusion process

SPECIFICATIONS

CAPACITY

Fuses Pipe Sizes:.....1/2" CTS – 1" IPS (16mm – 34mm)

MODELS

ACTS23301:.....1"IPS Max, 100V-120V, 50/60Hz, 100 Watt, 1 Phase Input Voltage Requirement

ACTS23302:.....1"IPS Max, 200V-240V, 50/60Hz, 100 Watt, 1 Phase Input Voltage Requirement

ACTS23303:...32mm Max, 100V-120V, 50/60Hz, 100 Watt, 1 Phase Input Voltage Requirement

ACTS23304:...32mm Max, 200V-240V, 50/60Hz, 100 Watt, 1 Phase Input Voltage Requirement

POWER

Heater Power:100 Watt

Facer Power:Hand-operated with 3/8" square drive

WEIGHT

Machine:.....3.6 lbs (1.63 Kg)

Facer:.....1.8 lbs (.82 Kg)

Heater:.....2.5 lbs (1.13 Kg)

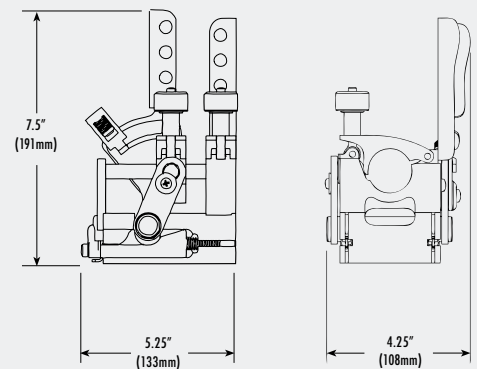

1LC

INCLUSIONS

The 1LC includes fusion machine, heater, facer, insulated heater sling, ratchet wrench, screw/driver kit and case. Specifications subject to change without notice.

