

# MINI-Mc®

Fusion Capability for 1/2" CTS to 1" IPS (16mm - 34mm)



## SPECIFICATIONS

### CAPACITY

Fuses Pipe Sizes:..... 1/2" CTS - 1" IPS (16mm - 34mm)

### MODELS

CTS07901:..... 1" IPS Mini-Mc

CTS08001:..... 32mm Mini-Mc

### POWER

Heater Power: ..... 300 Watt

Facer Power: ..... Hand-operated

### WEIGHT

Machine: ..... 3.5 lbs. (1.6 Kg)

Heater: ..... 3.24 lbs. (1.47 Kg)

Ratchet Facer: ..... 0.54 lbs. (0.24 Kg)

Knurled Facer: ..... 0.25 lbs. (0.11 Kg)

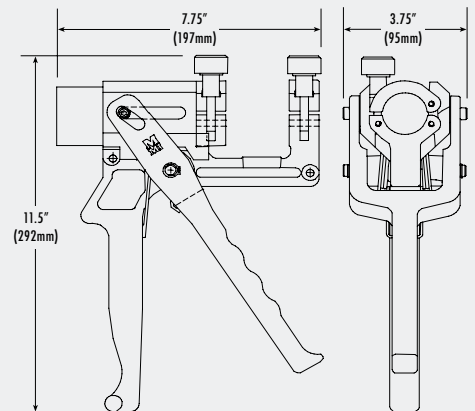

MINI-MC

### INCLUSIONS

The Mini-Mc includes fusion machine and screw/driver kit. Heater, facer and inserts are sold separately. Specifications subject to change without notice.

## OVERVIEW

One of McElroy's smallest fusion machines, the **Mini-Mc®**, makes small diameter butt fusion projects simple. The Mini-Mc is compact, lightweight, highly reliable, accurate and rugged. Perfect for joining 1/2" CTS to 1" IPS (16mm to 34mm) service sizes, the Mini-Mc requires only one operator and works in the most difficult conditions.

McElroy's patented features and precision engineering provide joint integrity and minimal maintenance. The narrow clamp design provides for butt fusion with precise pipe alignment at the fusion joint. The heater is thermostatically controlled and has a durable anti-stick coating.

## FEATURES

- 2.3-to-1 mechanical advantage
- Jaws use same inserts as the 1LC
- Hand-operated
- Thermostatically controlled heater
- Knurled and Ratchet Facers available

